

VANSON VET 25

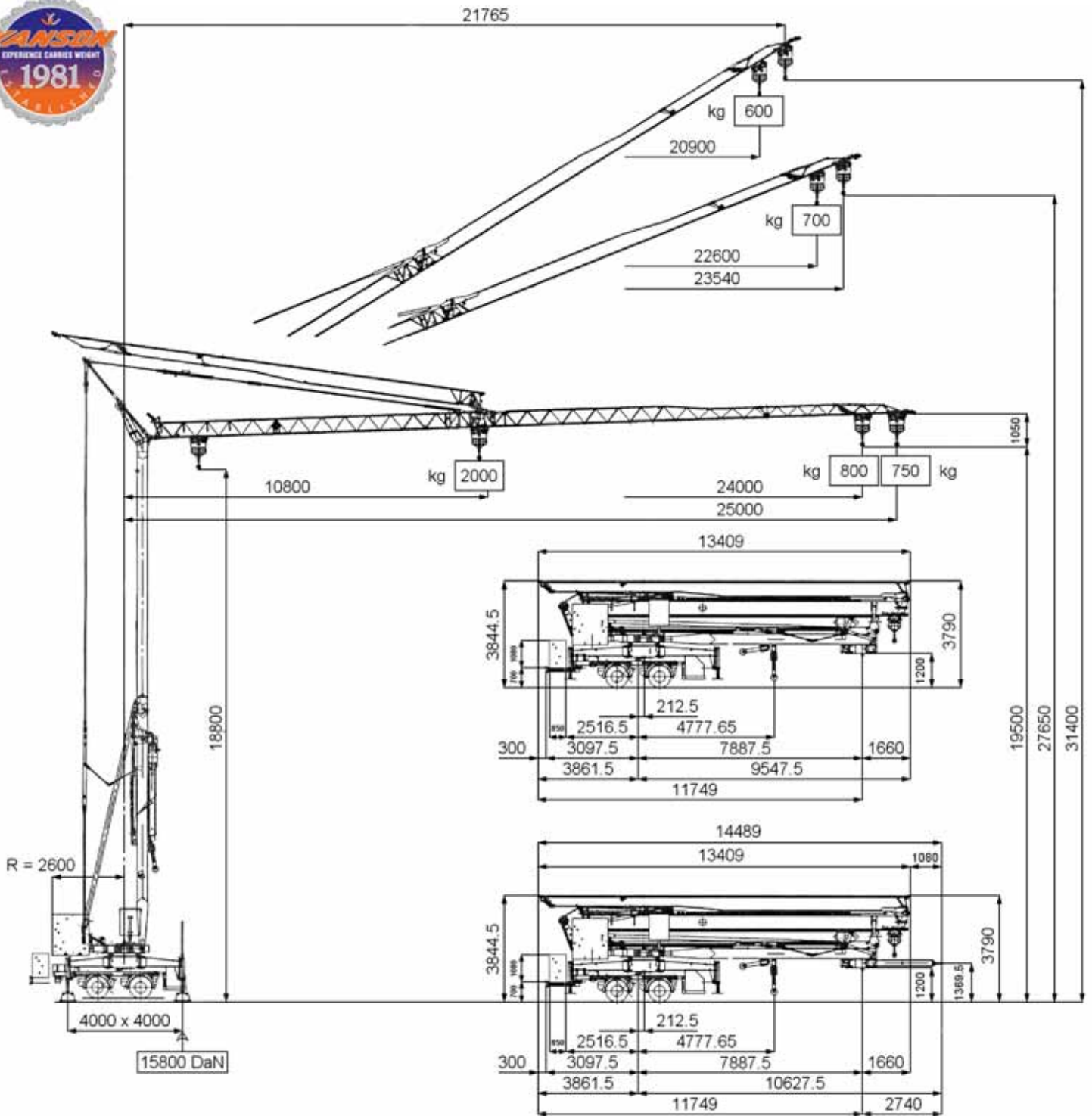

m	10.8	11.8	12.4	13.1	13.9	14.7	15.7	16.9	18.3	19.8	21.7	24	25
kg	2000	1800	1700	1600	1500	1400	1300	1200	1100	1000	900	800	750

CHARACTERISTICS		25 m
Height under hook	m	19.6
Height under hook with erected jib	m	32.55
Radius	m	25
Head capacity	kg	800
Max capacity	kg	2000
Hoist speed up to 800 kg	m/l'	36
Hoist speed up to 2000 kg	m/l'	18
Hoist speed up to 2000 kg	m/l'	4.5
Slewing speed	rpm	0.3 - 0.6 - 0.9

CHARACTERISTICS		25 m
Jib trolley speed	m/l'	17 - 34
Hoist motor power	kW	6.2 - 5.5 - 1.5
Assembly motor power	kW	3
Slewing motor	kW	1.84
Jib trolley motor	kW	2.2 - 1.1
Necessary electric power	kW	15
Ballast	kg	8400
Crane weight at carriage	kg	21050

VANSON VCT 25



VANSON CRANES LIMITED

Honey Pot Lane, Colsterworth, Grantham, Lincolnshire. NG33 5LY. Tel: (01476) 861011 Fax: (01476) 861014
E-mail: sales@vansoncranes.com Website: www.vansoncranes.com