

VANSON VC 18

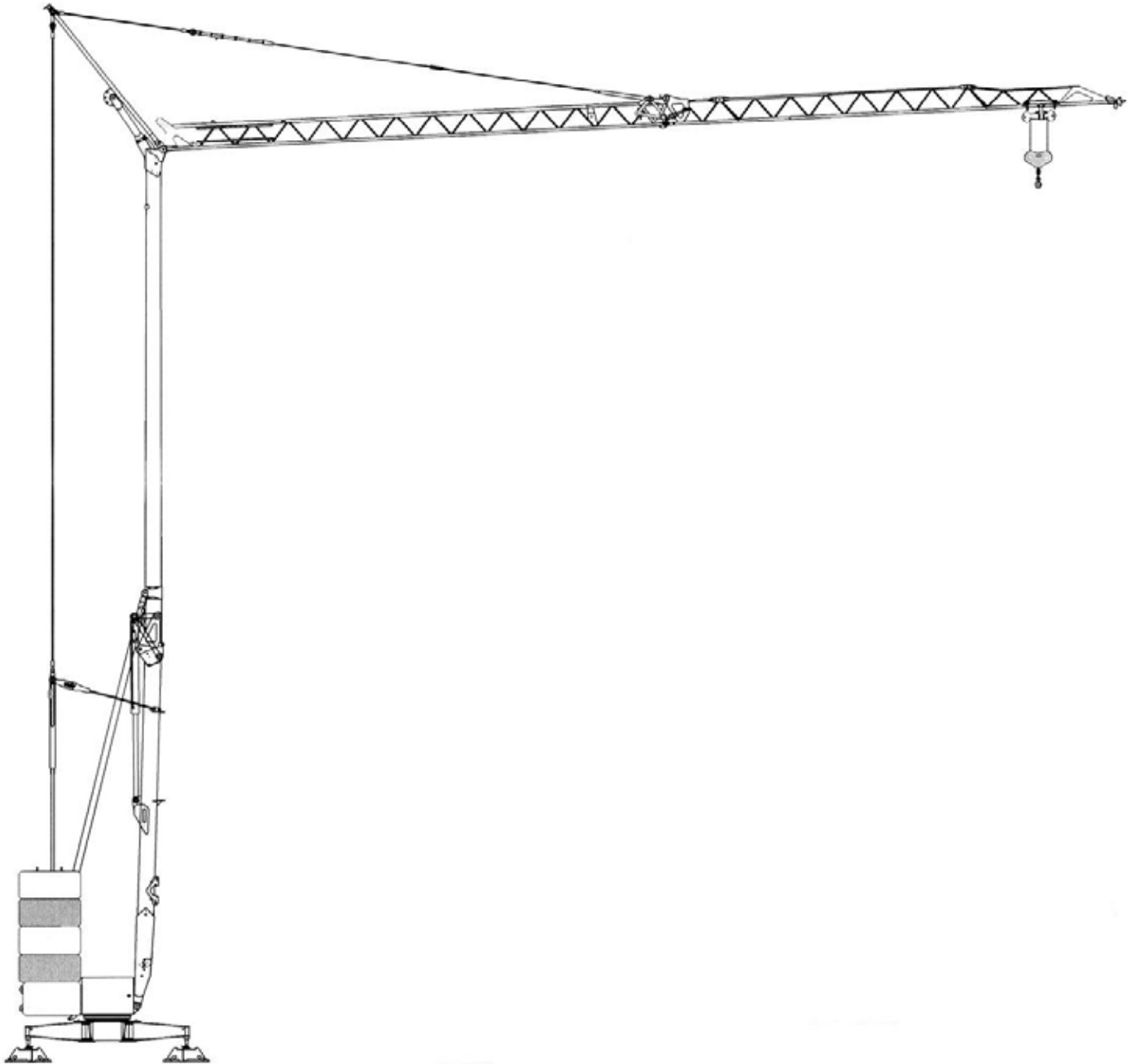

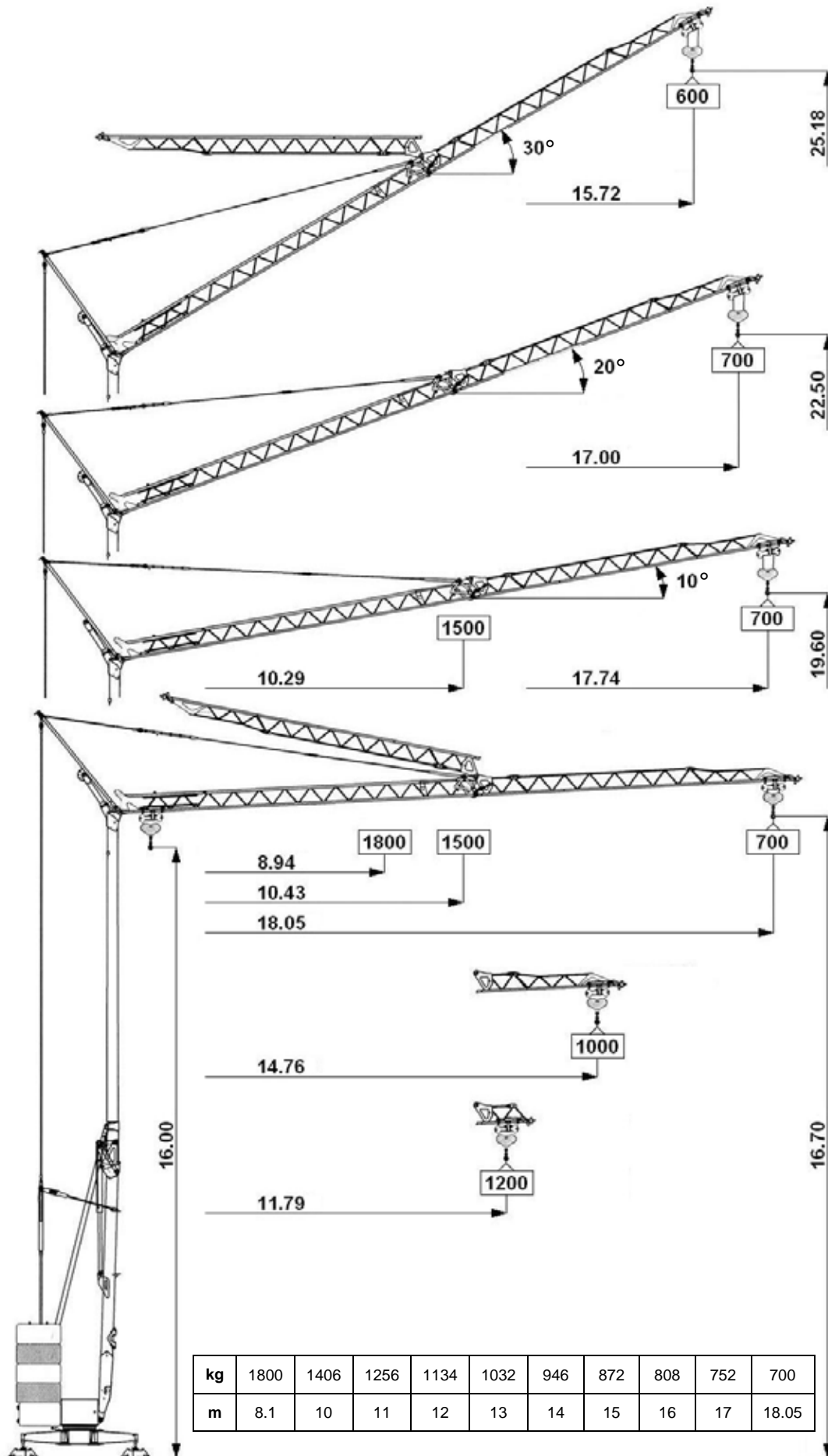







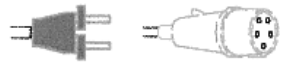
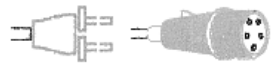
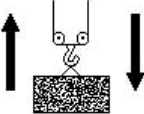





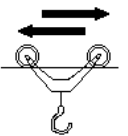

Hydraulic Self-Erecting Crane



VANSON VC 18



VANSON VC 18

 50 Hz V + 10% - 10%	 230V 3kVA (*) 24A			 400V 6kVA					
	 m/l' kg kW	 6.7 1800 7.5 (Inverter)	 13.5(*) 1800 7.5 (Inverter)	 23.5 700 7.5 (Inverter)	 6.7 1800 7.5 (Inverter)	 13.5 1800 7.5 (Inverter)	 37 700 7.5 (Inverter)	 6.7 1800 7.5 (Inverter)	 13.5 1800 7.5 (Inverter)
 m/l' kW	 11.8 1.85 (Inverter)			 18.9 1.85 (Inverter)			 35.4 (†26) 1.85 (Inverter)		
 m/l' kW	 0.4 1.2 (Inverter)			 0.83 1.2 (Inverter)			 1.15 1.2 (Inverter)		
 min kW	 5 1.5			 5850 kg + (2000 kg + 6800 kg)					

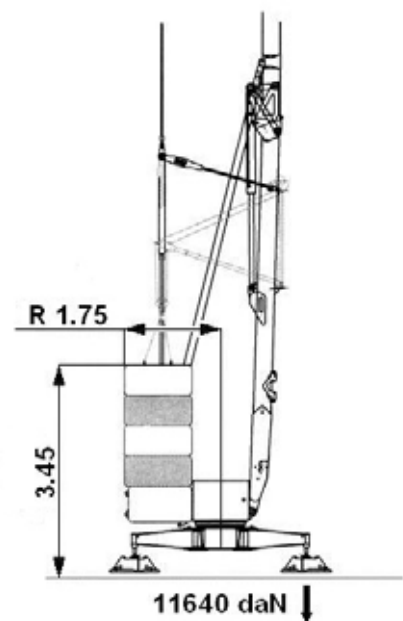
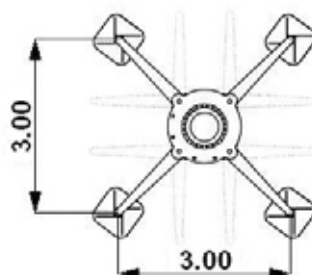
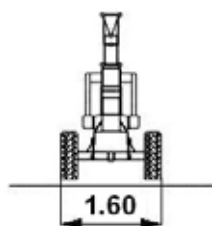
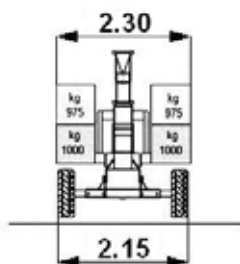
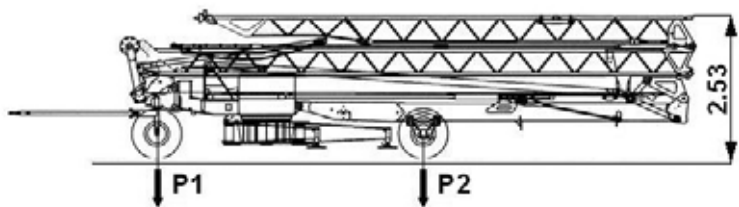
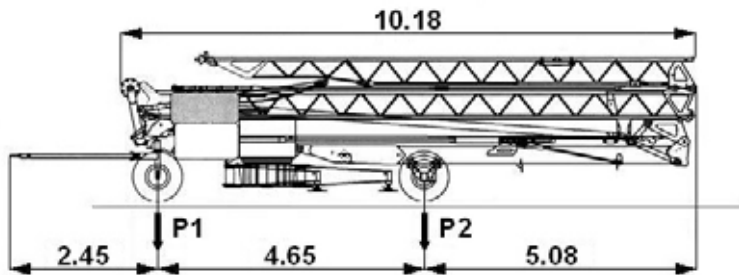

VANSON VC 18

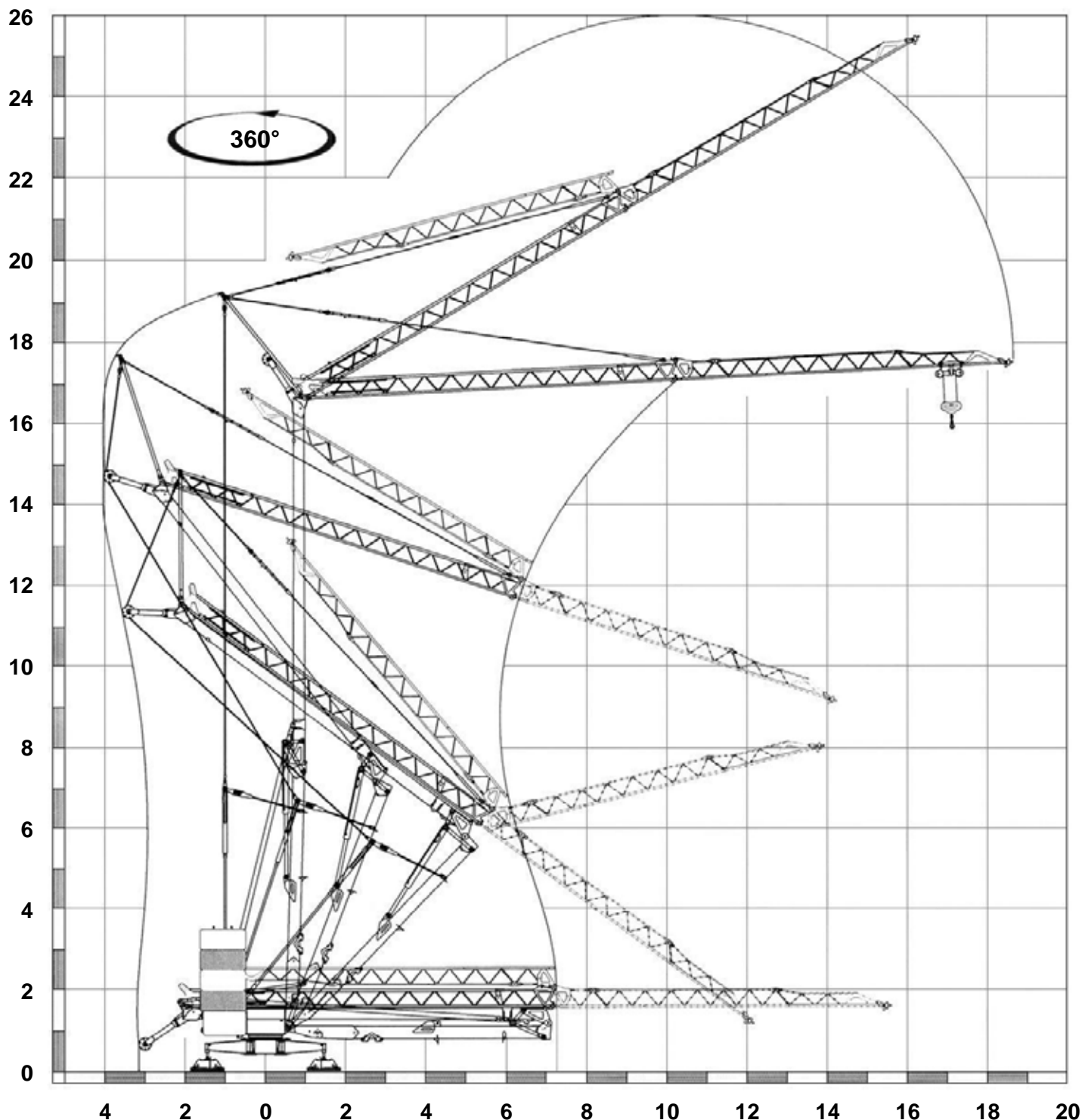

STANDARD FEATURES

3-speed lifting, rotation and trolley with inverter control, galvanised structure, counterweight, pull-up jib, translation trolley with motor and limit switch at base of gantry, operation with folden jib, cable-operated pushbutton remote control, guard for slewing ring and mechanisms, designed to allow installation of self-ballasting device and radio control, stainless steel electrical cabinet, documentation in accordance with EU standards.

VANSON CRANES LIMITED

Honey Pot Lane, Colsterworth, Grantham, Lincolnshire. NG33 5LY.
Telephone: + 44 (0) 1476 861011 Fax: + 44 (0) 1476 861014
E-mail: sales@vansoncranes.com Website: www.vansoncranes.com

January 2007