

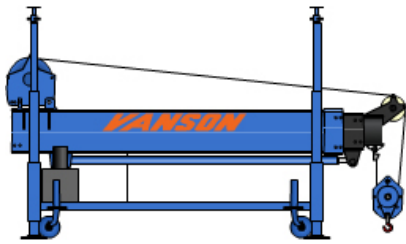

VANSON



PS32 Deck Loader

The VANSON PS32 Deck Loader is a lifting system for between floor installation handling construction material for multi level distribution and is ideal for, but not limited to, use with our retractable loading platforms. Upper floor installation is also possible with a bolted or ballasted installation.

The VANSON PS32 Deck Loader has a hydraulic telescopic jib extending 6m, with a rated capacity of 3,200kg on the hook along the full jib extension, and a maximum 2 fall height under hook of 120m.

The operator's low voltage electrical lever control with wander lead cable enables varied locations for clear line of site operation. The inverter controlled 25hp electric hoist winch provides 3 speeds for rapid material distribution, combined with the electro-hydraulic telescopic jib system for precise positioning.

Normally installed between the floors of the building and held in place by four screw jacks the VANSON PS32 Deck Loader can be moved on its castor wheels, or lifted by the dedicated lift points.

For safe operation a rated capacity indicator/limiter is fitted to the crane preventing overload. Hook control limits are also fitted.

For fitting out, maintenance, and refurbishment of buildings where vertical material distribution is required consider the VANSON PS32 Deck Loader as your practical vertical material handling machine.

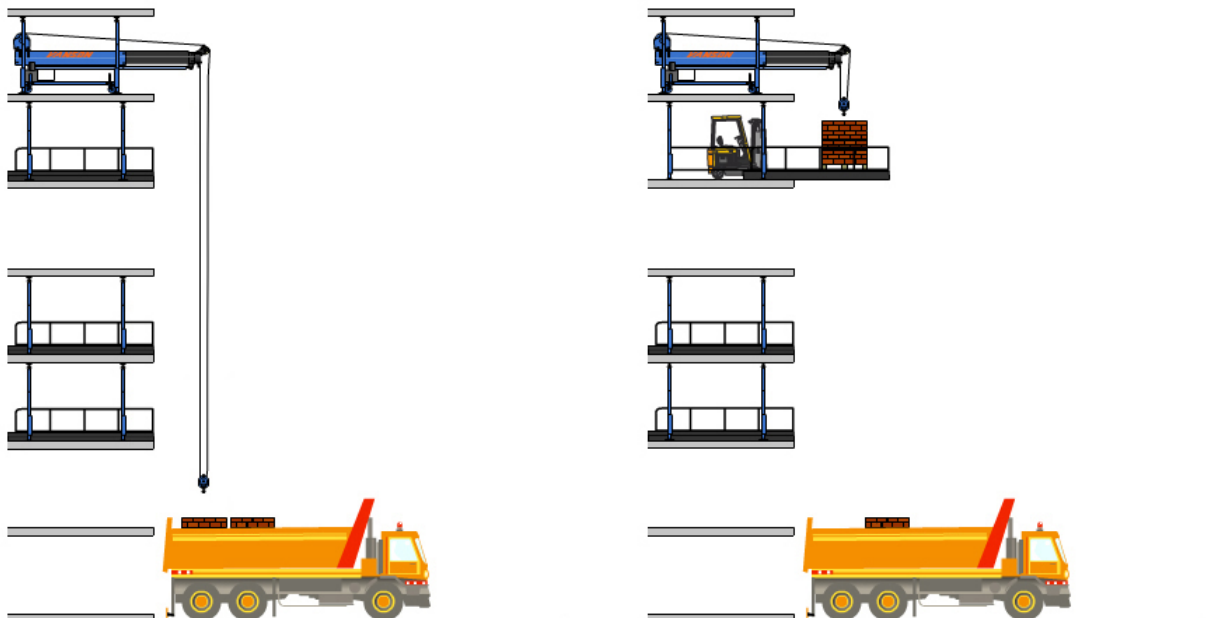



PS32 Deck Loader

Manufactured by:



Progetti Speciali S.r.l.

Web: www.progettispecialisrl.com

Marketed by:

VANSON CRANES Ltd

Email: sales@vansoncranes.com

Web: www.vansoncranes.com

Tel: 01476 861011

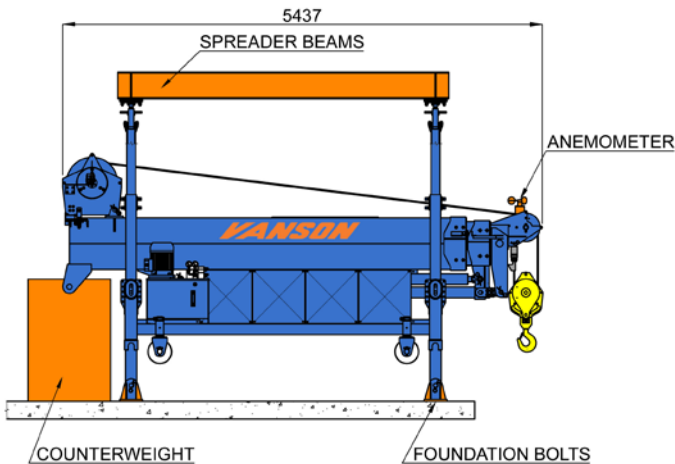
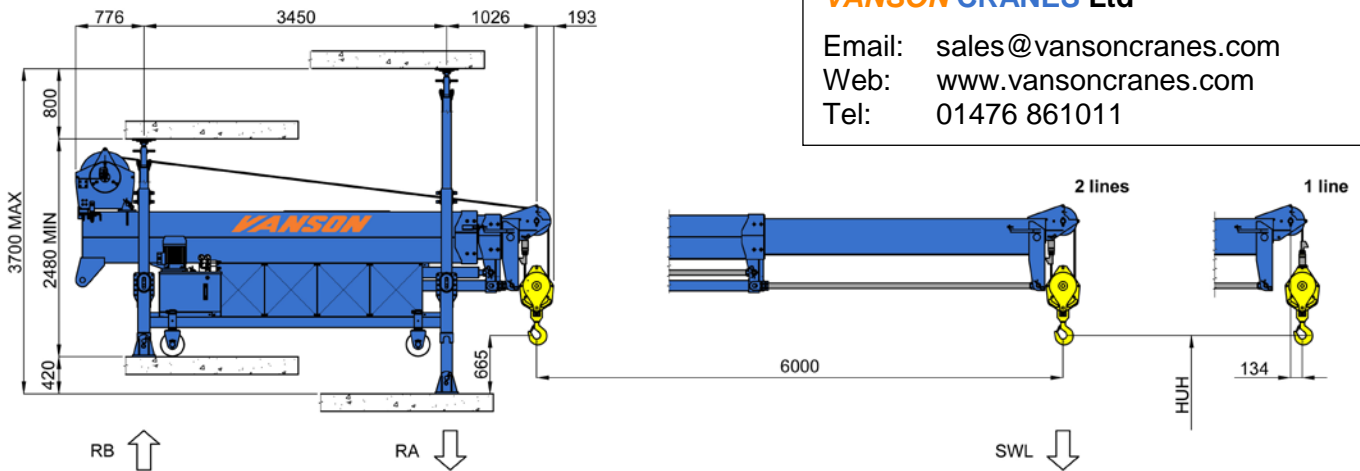

OPTIONS

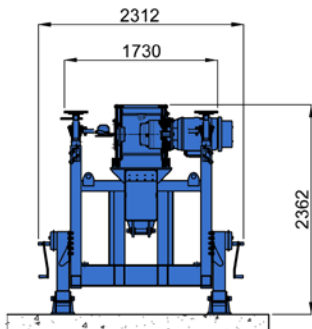

POWER SUPPLY

400/415 Volts 50/60 Hz 50 Amps

LOAD

	2 Ropes	1 Rope
SWL	3250 kg	1600 kg
HUH	120 m	240 m

SPEED

	OUT	IN
1st	5 m/min	10 m/min
2nd	30 m/min	60 m/min
3rd	60 m/min	120 m/min
BOOM	2.0 min	1.2 min

REACTIONS ON JACKS

	Boom OUT	Boom IN
RA	+ 7.5 t	+ 4.2 t
RB	- 3.5 t	- 1.9 t
Weight	4.5 t	

PATENT APPLIED FOR

VANSON CRANES LIMITED

Honey Pot Lane, Colsterworth, Grantham, Lincolnshire. NG33 5LY. Tel: (01476) 861011 Fax: (01476) 861014
E-mail: sales@vansoncranes.com Website: www.vansoncranes.com

August 2011