

RAIVAN LR60 TOWER CRANE

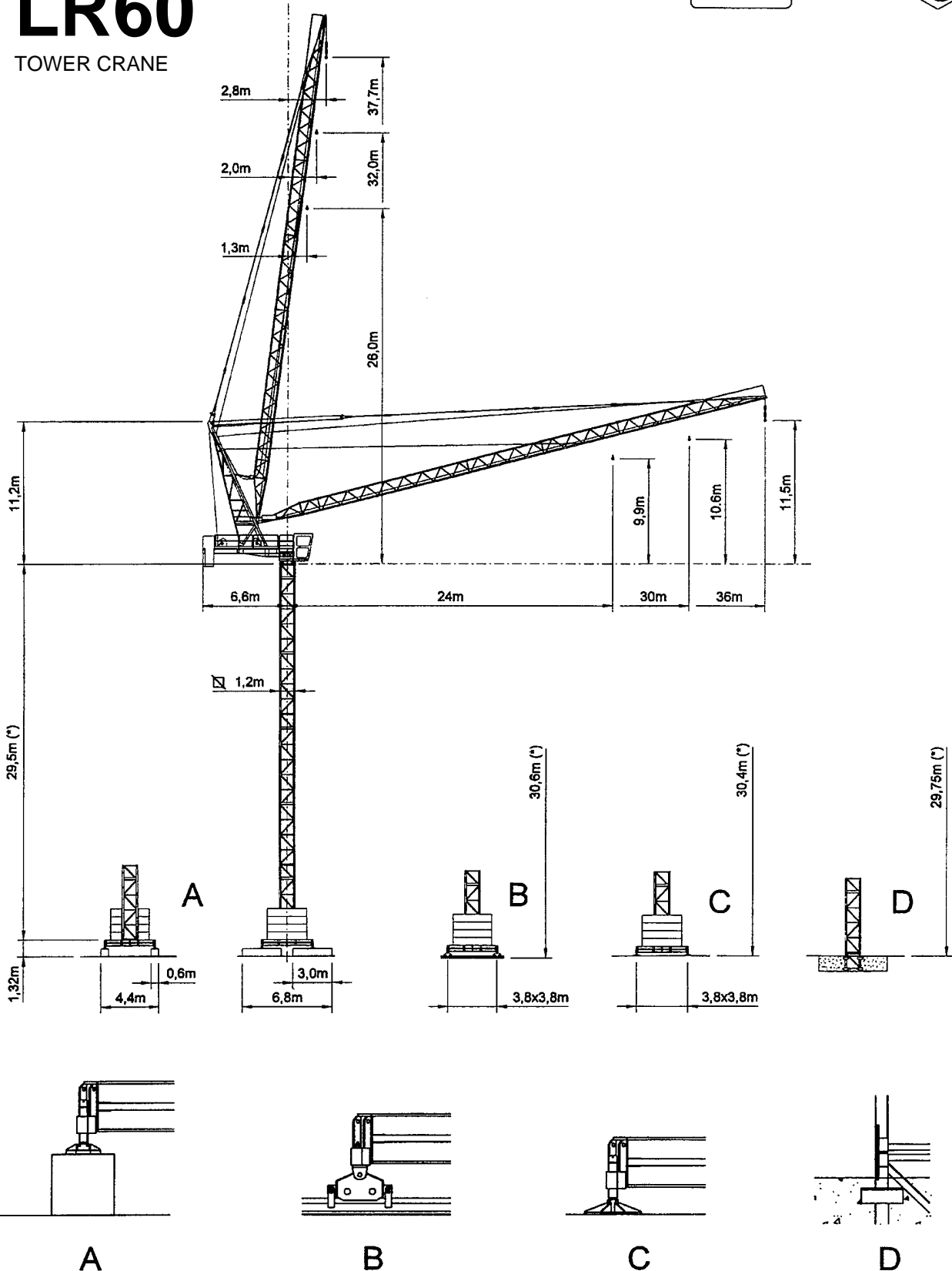

VANSON

LR60 RI FLOOR CLIMBING

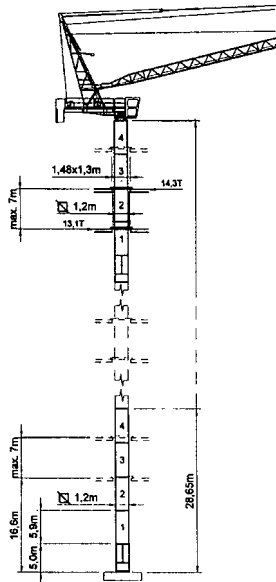

LR60 HC EXTERNAL CLIMBING

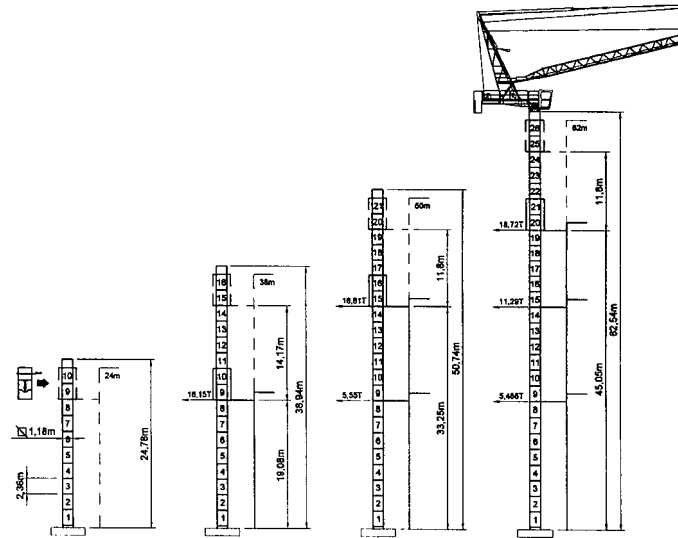

ASSEMBLING SEQUENCE

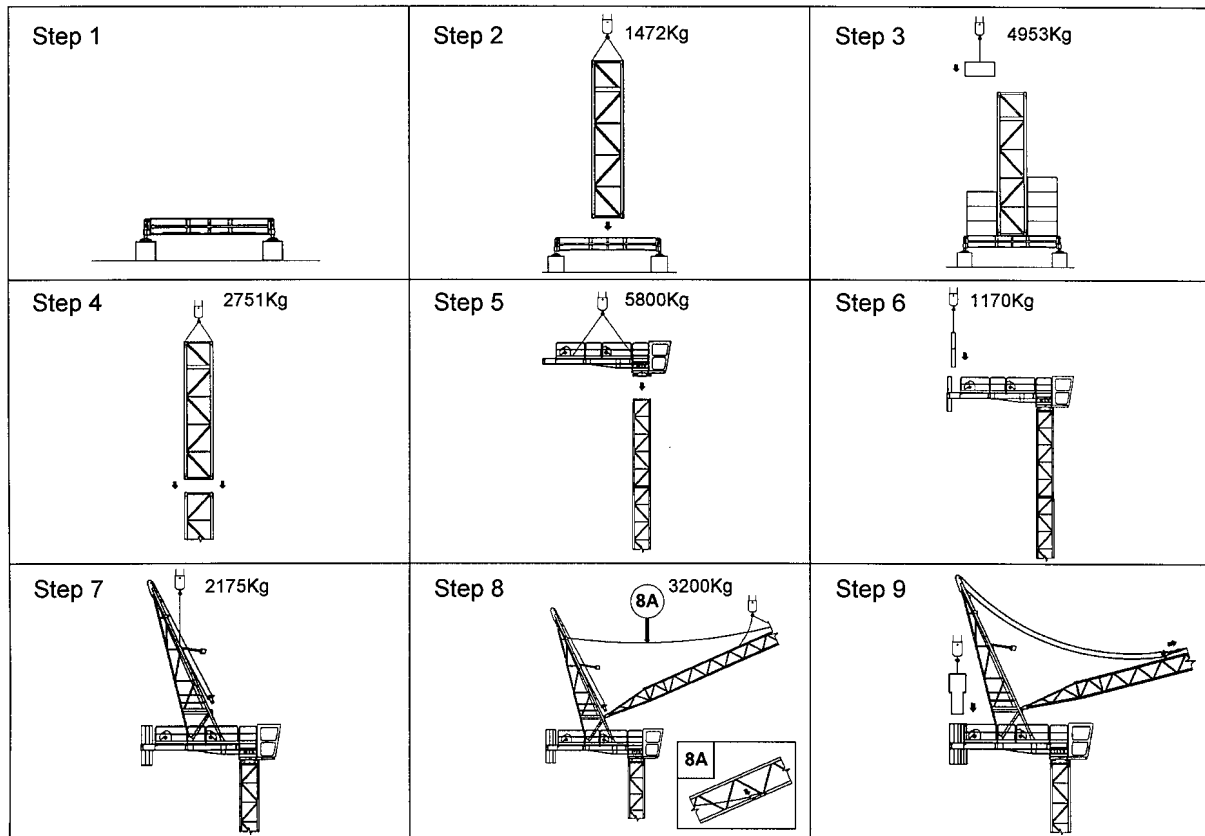

RAIVAN LR60

TOWER CRANE

LOAD-RADIUS CHARACTERISTICS (4000Kg)

JIB	m	36	30	24
RADIUS (m)	17	4000		
	18	3767	4000	4000
	19	3521	3746	3919
	20	3297	3517	3691
	21	3092	3307	3482
	22	2904	3114	3290
	23	2731	2936	3113
	24	2571	2772	2950
	25	2422	2620	
	26	2284	2478	
	27	2156	2347	
	28	2036	2224	
	29	1923	2108	
	30	1818	2000	
	31	1719		
	32	1625		
	33	1537		
	34	1454		
	35	1375		
	36	1300		



SLEWING

SPEED:
0 - 0.76 r.p.m
POWER:
3.2 Kw



LUFFING

ANGLE:
14.5° - 85°
SPEED:
1.73 m/min
POWER:
18.4 Kw



RAIL

SPEED:
14 m/min
POWER:
2 x 2.9 Kw

HOISTING WINCH HP.40

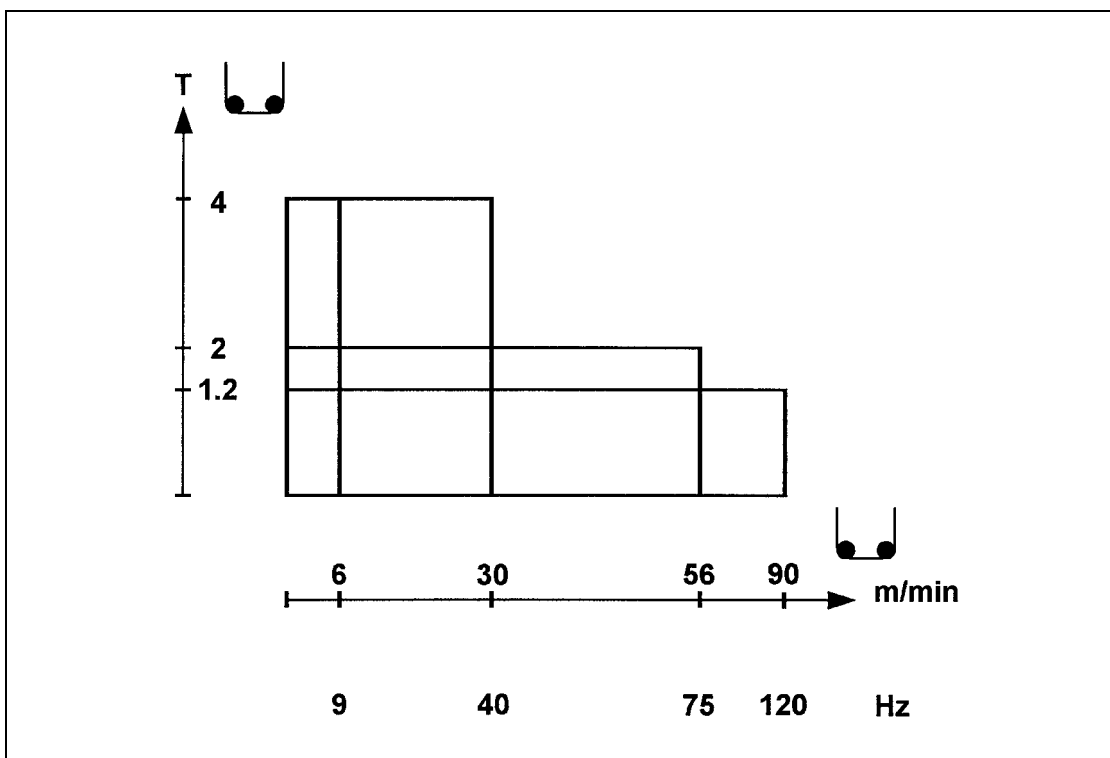

H. U. H., MAX. BASE BALLAST AND CORNER PRESSURE

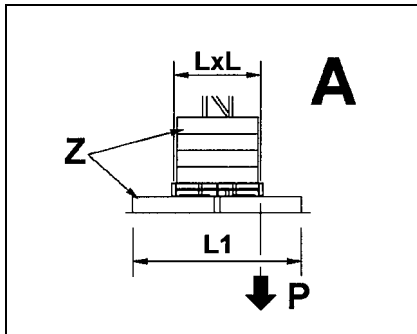

ON UNDERCARRIAGE

H.T (m)	max. Z (t)	P (kN)
30.0 (*)	59.39	542
24.0	49.48	469
18.0	39.57	314
12.0	29.67	250

ON UNDERCARRIAGE

H.T (m)	max. Z (t)	P (kN)
41.4 (*)	80.6	752
37.0	74.7	714
31.1	57.0	550
25.2	45.2	405
19.3	33.4	294

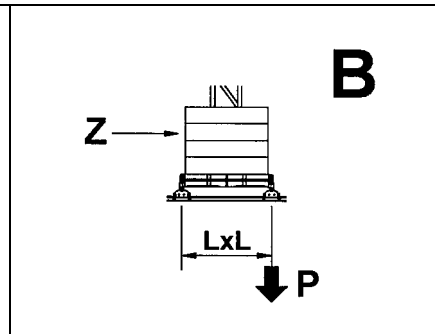

L = 3.8 m / L1 = 6.8 m

H.T (m)	max. Z (t)	P (kN)
30.0 (*)	59.44	545
24.0	49.53	470
18.0	39.62	315
12.0	29.72	250

L = 4.5 m / L1 = 8.1 m

H.T (m)	max. Z (t)	P (kN)
41.1 (*)	82.6	743
36.7	76.7	706
30.8	59.0	542
24.9	47.2	398
19.0	35.4	303

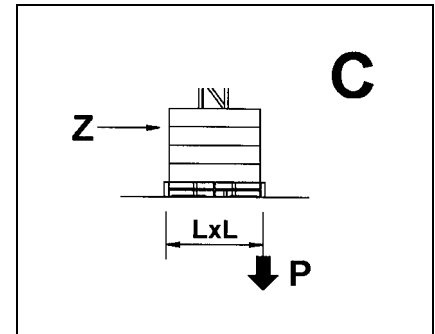

(□ 1.2m)

H.T (m)	max. Z (t)	P (kN)
30.0 (*)	59.44	541
24.0	49.53	468
18.0	39.62	313
12.0	29.72	250

(□ 1.5m)

H.T (m)	max. Z (t)	P (kN)
40.8 (*)	82.6	735
36.4	76.7	697
30.5	59.0	534
24.6	47.2	391
18.7	35.4	299

(*) – Not for 36m jib

ON FOUNDATION ANCHORS

	H.T (m)	12.0	18.0	24.0	28.0 (*)	30.0	34.0 (*)
	T (kN)	441	542	781	959	943	1131
	P (kN)	552	637	883	1068	1049	1243
	q max. (daN/cm ²)	0.84	0.99	1.42	1.89	1.55	2.06
	L (m)	5.2					5.4

	H.T (m)	12.0	17.9	23.8	29.7	35.6	40.0
	T (kN)	375	413	552	778	1037	1256
	P (kN)	475	523	673	910	1180	1406
	q max. (daN/cm ²)	0.717	0.763	0.94	1.258	1.794	2.475
	L (m)	5.8					