

VANSON LCL 20.1

Floor Mounted Crane Configuration

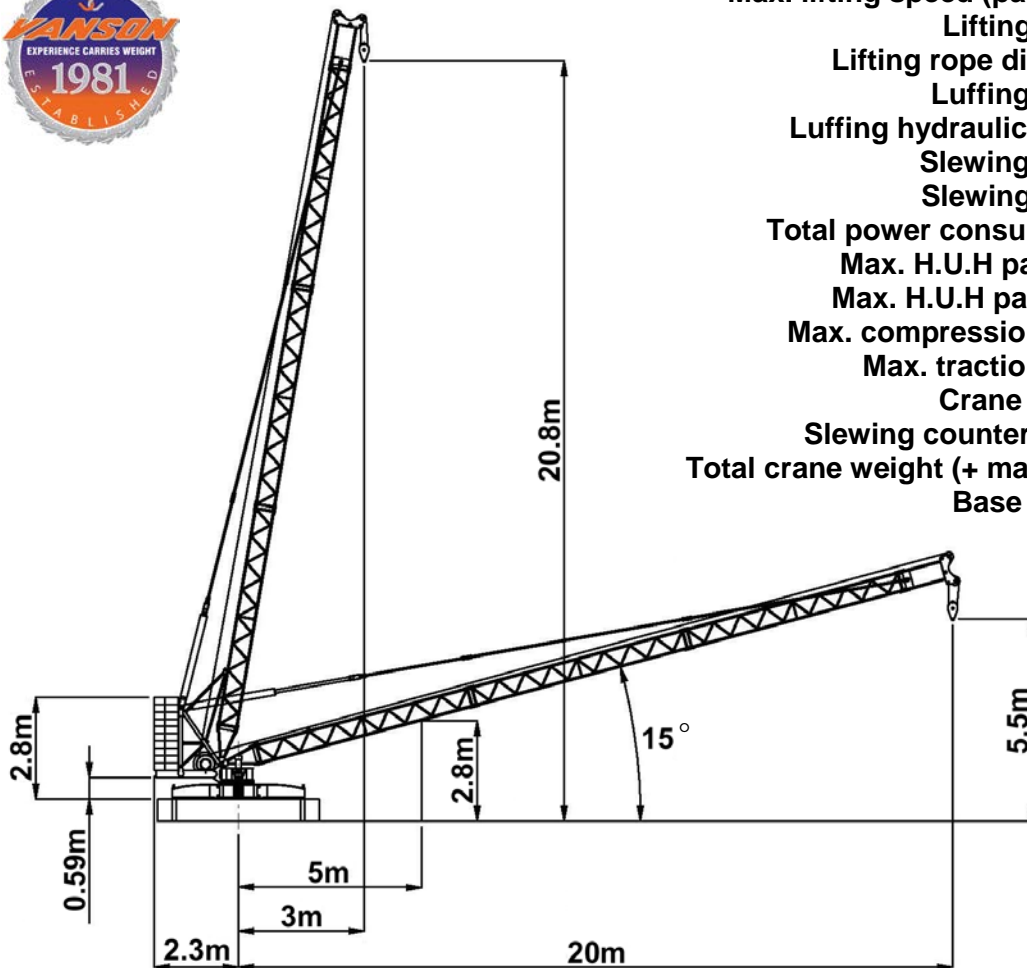

Max. lifting speed (partline I)	80 m/min
Lifting motor	9.5 kW
Lifting rope diameter	10 mm
Luffing speed	60 s
Luffing hydraulic piston	7.5 kW
Slewing speed	0.9 r.p.m.
Slewing motor	1.5 kW
Total power consumption	26 KVA
Max. H.U.H partline I	200 m
Max. H.U.H partline II	100 m
Max. compression force	13700 kg
Max. traction force	7300 kg
Crane weight	4200 kg
Slewing counterweight	5000 kg
Total crane weight (+ max load)	12700 kg
Base ballast	16000 kg

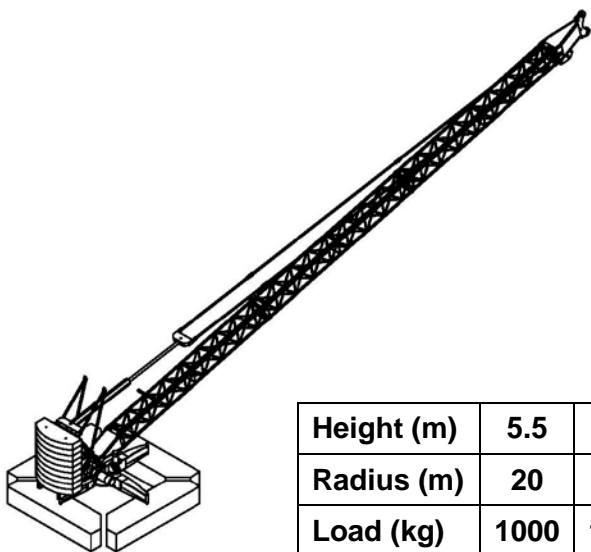

Permitted Loads

Height (m)	5.5	11.9	14.4	16.3	17.7	18.9	19.8	20	20.3	20.8
Radius (m)	20	18	16	14	12	10	8	6	5.5	3
Load (kg)	1000	1110	1250	1430	1660	2000	2550	3300	3500	3500

VANSON LCL 20.1

Tower Crane Configuration

Max. lifting speed (partline I)	80	m/min
Lifting motor	9.5	kW
Lifting rope diameter	10	mm
Luffing speed	60	s
Luffing hydraulic piston	7.5	kW
Slewing speed	0.9	r.p.m.
Slewing motor	1.5	kW
Total power consumption	26	KVA
Max. H.U.H partline I	200	m
Max. H.U.H partline II	100	m
Max. compression force	13700	kg
Max. traction force	7300	kg
Crane weight	4200	kg
Slewing counterweight	5000	kg
Total crane weight (+ max load)	12700	kg

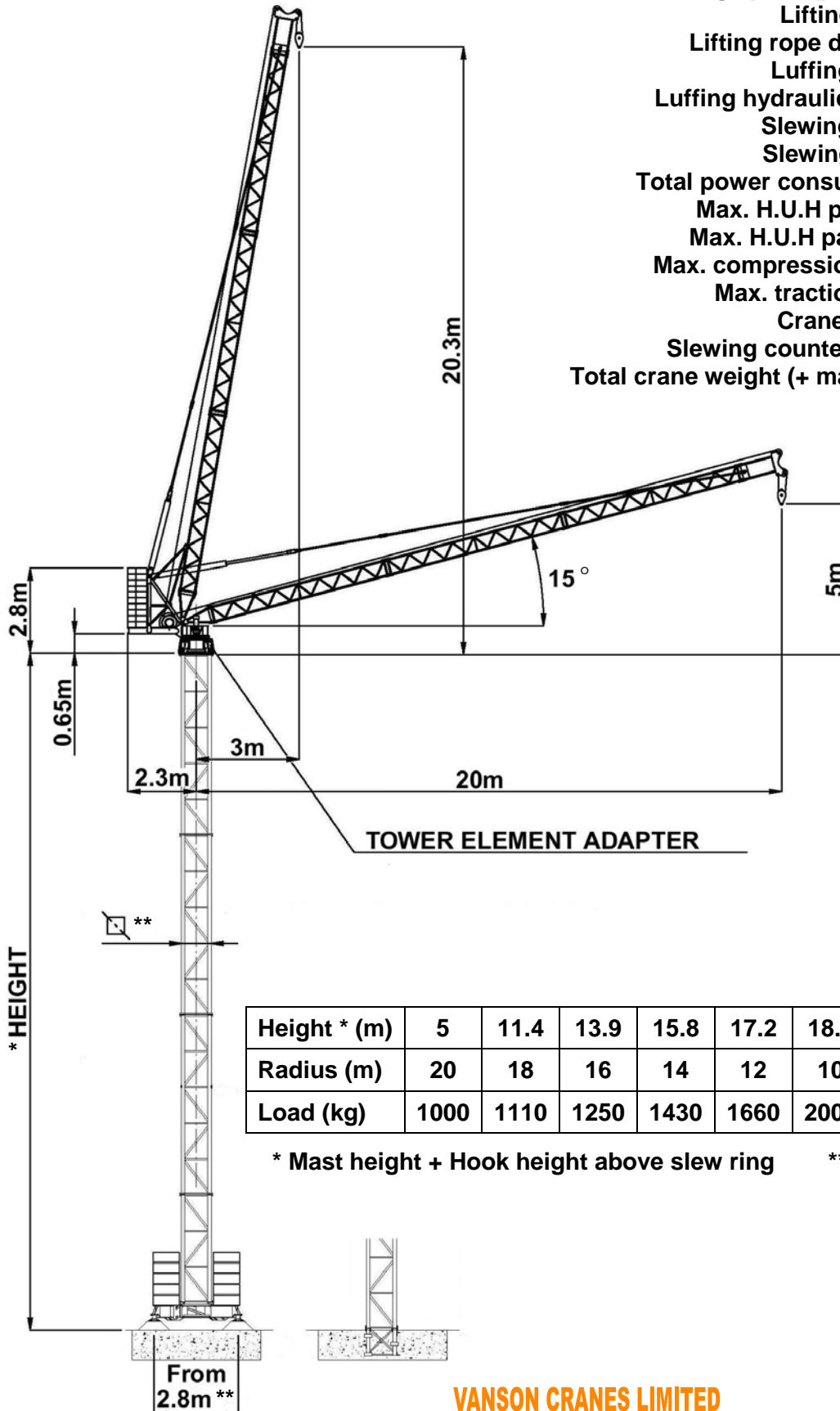

Permitted Loads

Height * (m)	5	11.4	13.9	15.8	17.2	18.4	19.3	19.5	19.8	20.3
Radius (m)	20	18	16	14	12	10	8	6	5.5	3
Load (kg)	1000	1110	1250	1430	1660	2000	2550	3300	3500	3500

* Mast height + Hook height above slew ring

** Depending on mast height

VANSON CRANES LIMITED

Honey Pot Lane, Colsterworth, Grantham, Lincolnshire. NG33 5LY.

Telephone: +44 (0) 1476 861011 Fax: +44 (0) 1476 861014

E-mail: sales@vansoncranes.com Website: www.vansoncranes.com